

# BRAMEC®

## 2" CONCENTRIC VENT KIT

- **Simplifies the installation of high efficiency furnaces**
- **Requires only one hole to be cut rather than two**
- **Saves time & money during installation**

**Bramec Corporation**  
**[www.bramec.com](http://www.bramec.com)**  
**Made in China**

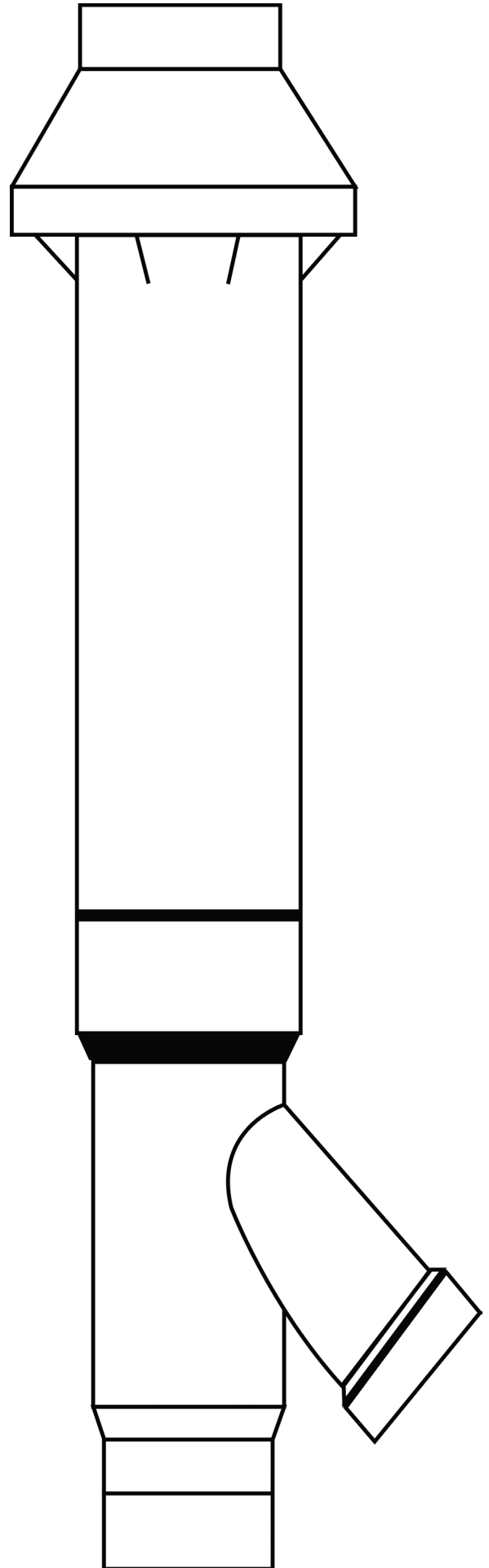

# BRAMEC 2" CONCENTRIC VENT KIT INSTALLATION

## Roof Termination

1. Determine the best location for the termination kit.

**NOTE:** A roof termination is less susceptible to damage. It has reduced chances for intake contaminants and less visible vent vapors.

2. Cut a hole in the roof 4" in diameter for 2" concentric vent kit.

3. Partially assemble concentric vent termination kit.

a. Cement Y concentric fitting to larger diameter kit pipe

(see Fig. 1).

b. Cement vent cap to smaller diameter kit pipe (see Fig. 1).

4. Install Y concentric fitting and pipe assembly through the hole in the roof and field supplied boot/flashing. **NOTE:** Do not allow insulation or other material to accumulate inside the pipe assembly when installing through the hole.

5. Secure assembly to roof structure as shown in Fig. 4 using field supplied metal strapping or equivalent support material.

**NOTE:** Ensure termination height is above the roof surface or anticipated snow level (1' in USA or 1 1/2' in Canada) as shown in Fig 3.

**NOTE:** If assembly is too short to meet height requirements, the two pipes supplied in the kit may be replaced by using same diameter, field supplied SDR-26 PVC (D2241) pipe. Do not extend dimension D more than 60" (See Fig. 4.) **DO NOT USE COUPLINGS TO EXTEND PIPE.**

**NOTE:** When shortening the length of the concentric vent, the inner pipe is longer than the outer pipe. Make sure you cut the same amount from each pipe. **DO NOT** make the pipes equal in length.

6. Install vent cap and small diameter pipe assembly in roof penetration assembly. Ensure small diameter pipe is cemented and bottomed in Y concentric fitting.

7. Cement air inlet and exhaust vent pipes to concentric vent termination assembly. See Fig. 4 for proper pipe attachment.

8. Operate boiler through a heating cycle to ensure air inlet and exhaust vent pipes are properly connected to concentric vent termination connections.

**NOTE:** Multiple vertical venting is not allowed

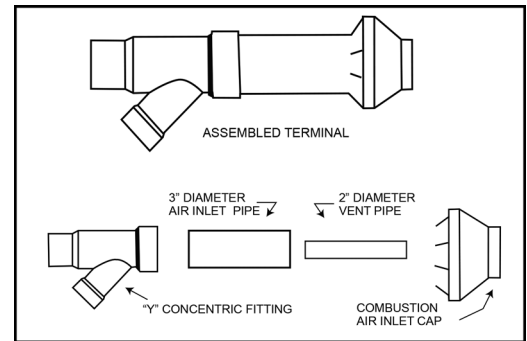

Figure 1 - Vent Terminal Assembly

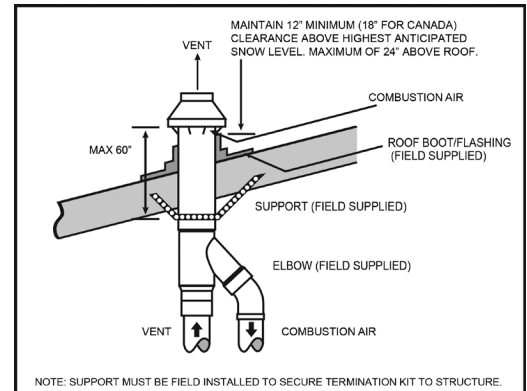

Figure 4 - Roof Installation

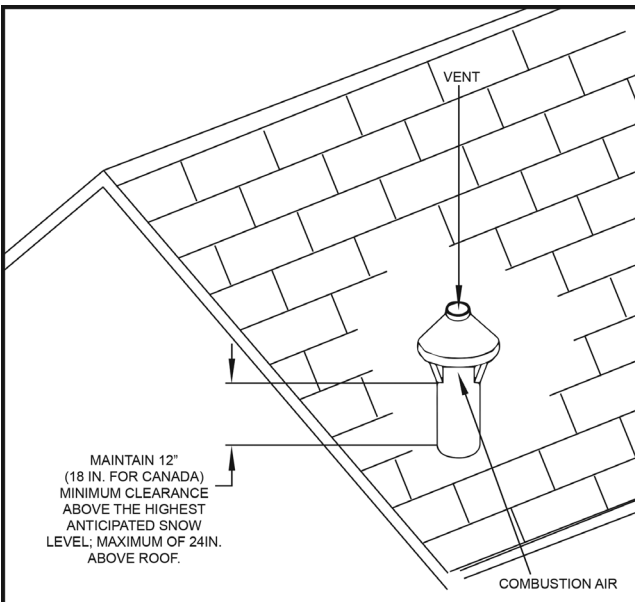

Figure 3 - Roof Termination

### WARNING:

It is very important to properly glue all joints. Failure to do so can result in property damage, serious personal injury, or death.

# BRAMEC 2" CONCENTRIC VENT KIT INSTALLATION

## Sidewall Termination

1. Determine the best location for the termination kit.
  - a. Position termination kit where vent vapors will not damage plants, shrubs, air conditioning equipment, of the existing structure.
  - b. Position termination kit so it will not be affected by wind (which may cause recirculation of combustion products), airborne leaves, light snow, or fertilizer.
  - c. Position termination kit where it will not be subjected to damage from foreign objects, such as stones, balls, etc.
  - d. Position termination kit where the vent noise will not be objectionable to abutters.

2. Cut a hole in the sidewall 4" in diameter for 2" concentric vent kit.
3. Partially assemble concentric vent termination kit.

- a. Cement the Y concentric fitting to larger diameter kit pipe (see Fig. 1).
  - b. Cement the vent cap to the smaller diameter kit pipe (see Fig. 1).

4. Install Y concentric fitting and pipe assembly through the hole.

**NOTE:** Do not allow insulation or other materials to accumulate inside pipe assembly when installing through hole.

5. Install vent cap and small diameter pipe assembly in Y concentric fitting and large pipe assembly. Ensure small diameter pipe is bottomed and cemented in Y concentric fitting.

6. Secure assembly to structure using field supplied metal strapping or equivalent support material (see Fig. 6).

**NOTE:** Ensure termination location clearance dimensions are as shown in Fig. 5.

**NOTE:** If assembly needs to be extended to allow sidewall thickness requirement, the two pipes supplied in the kit may be replaced by using the same diameter, field supplied SDR-26 (D2241) pipe. Do not extend Dimension D to more than 60" (see Fig. 6). **DO NOT USE COUPLINGS TO EXTEND PIPE.**

7. Cement air inlet and exhaust vent pipes to concentric vent termination assembly. See Fig. 6 for proper pipe attachment.
8. Operate boiler/heater through a heating cycle to ensure air inlet and exhaust vent pipes are properly connected to concentric vent termination connections.
9. Allow 8" center-to-center distance between concentric vent terminations on multiple boiler installations (see Fig. 7).

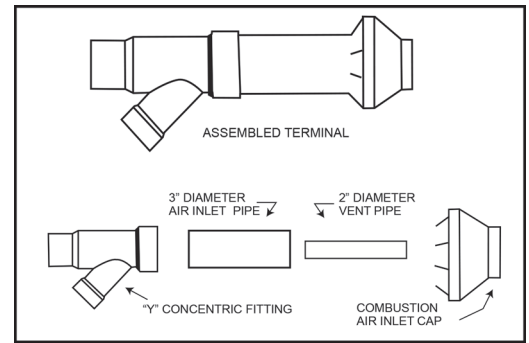

Figure 1 - Vent Terminal Assembly

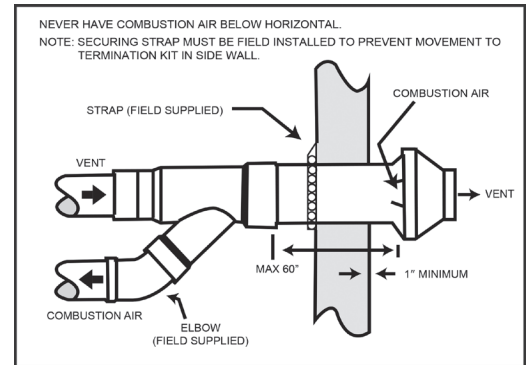

Figure 6 - Sidewall Installation

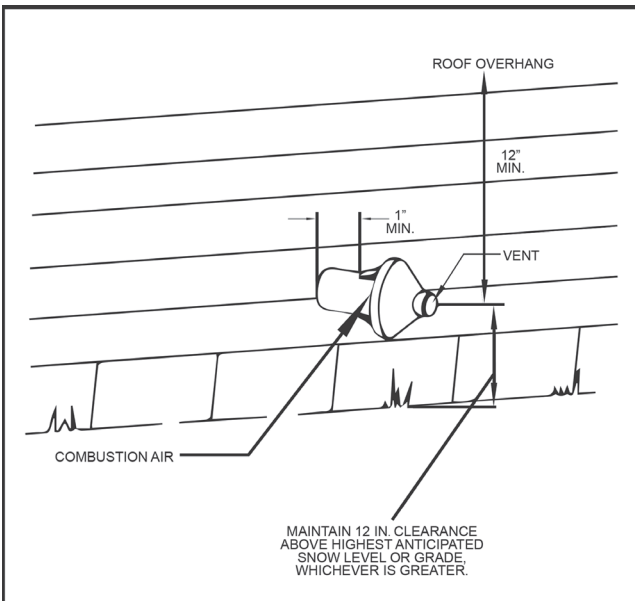

Figure 5 - Sidewall Termination

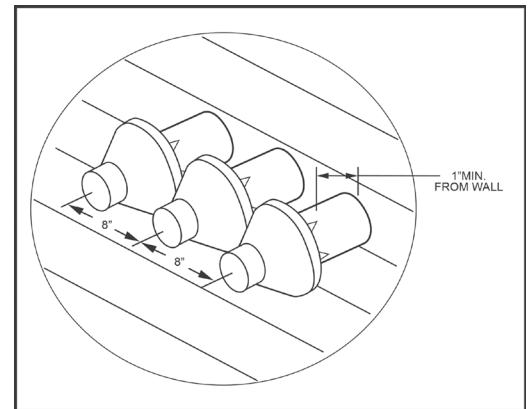

Figure 7 - Multiple Installations

**WARNING:**  
 It is very important to properly glue all joints. Failure to do so can result in property damage, serious personal injury, or death.

# Bramec 2" Concentric Vent Kit Installation

These instructions cover installation of the 2" concentric vent termination kit **ONLY**.

## General

The Concentric Vent allows both the intake for combustion air and the exhaust vent to pass through a standard roof or sidewall. This is an alternative to the standard two pipe intake/vent shown in the basic furnace installation instructions. Follow these instructions as well as the basic furnace installation instruction for installation of the intake/vent pipe(s) and all furnace installation procedures.

Refer to the furnace installation instructions for intake/vent pipe sizing information.

**NOTE:** The Concentric Vent reduces the allowable intake/vent piping length by 5 feet from that listed in the basic furnace installation instructions.

### WARNING:

Do not use the Concentric Vent kit for anything other than a Category IV furnace. Failure to follow this warning could result in fire, personal injury or death.

### WARNING:

Do not operate the furnace until the installation and assembly of the Concentric Vent and all piping are completed. Failure to follow this warning could result in product damage or improper operation, personal injury or death.

## This Kit contains the following parts:

- Combustion Air Inlet Cap
- Air Inlet Pipe
- Vent Pipe
- Intake/Vent Concentric "Y"

Pipe and fittings are required to complete installation (user supplied). The combustion air and vent pipe fittings must conform to ANSI and ASTM standards D1785, F891, D2665, D2241, D2661, or F628. Pipe cement and primer must conform to ASTM standards D2564 or D2235.

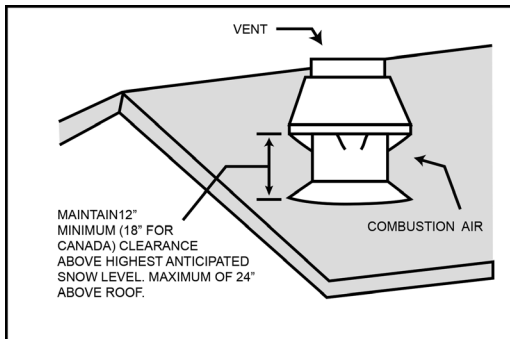
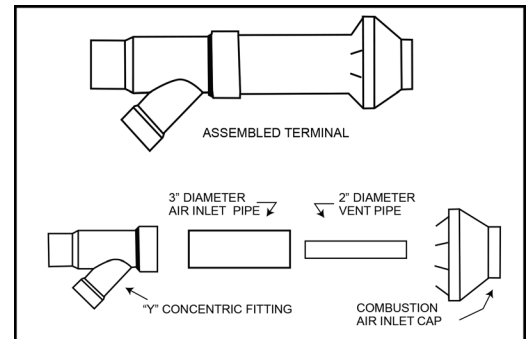

INTAKE/VENT NOM. PIPE SIZE	OVERALL ASSEM'T'D LENGTH <sup>1</sup>	INTAKE PIPE OUTSIDE DIAMETER	AIR INLET PIPE LENGTH <sup>2</sup>
2"	34-3/4"	3-1/2"	19-1/2"
3"	39-1/8"	4-1/2"	24"

1. Shipping dimension. This may be field modified by cutting or extending both the intake and exhaust pipes. 12" is the minimum allowable length and 60" is the maximum allowable length for this dimension. SDR-26 PVC (D2241) only may be used for extending pipes. Do not extend pipes with same diameter PVC or couplings.
2. This dimension will change if the intake/vent pipes are lengthened or shortened.

### NOTICE:

Some local code inspectors are not familiar with concentric vents. Be sure to check local code requirements and acceptability prior to installation.

# BRAMEC®

## 3" CONCENTRIC VENT KIT

- **Simplifies the installation of high efficiency furnaces**
- **Requires only one hole to be cut rather than two**
- **Saves time & money during installation**

**Bramec Corporation**  
**[www.bramec.com](http://www.bramec.com)**  
**Made in China**

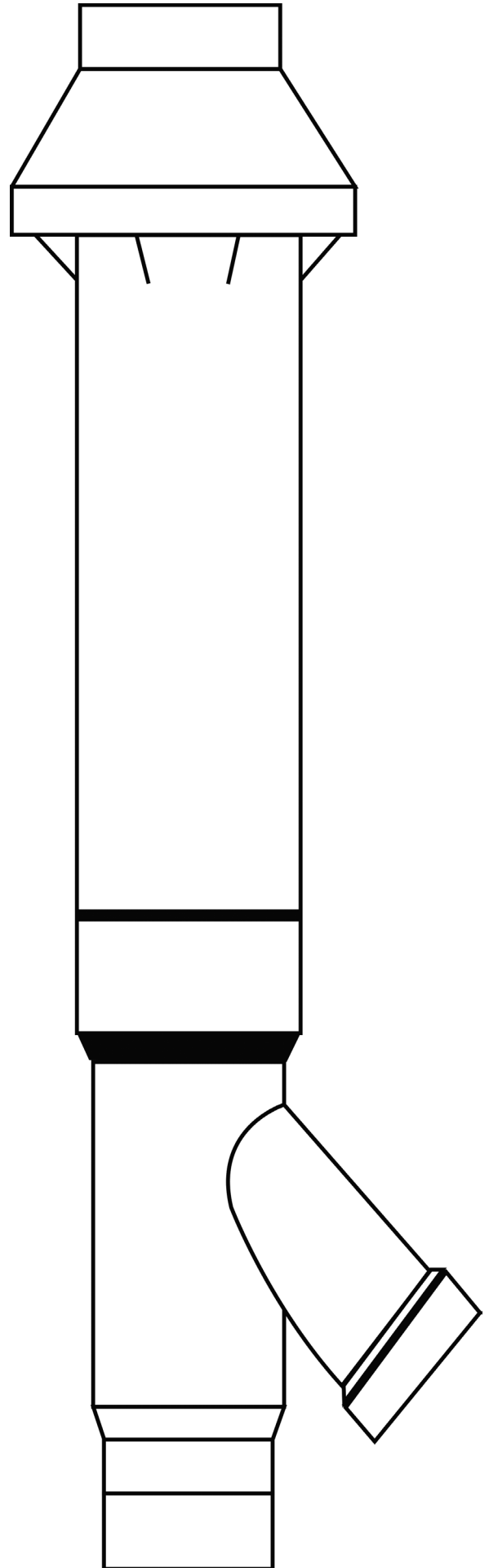

# BRAMEC 3" CONCENTRIC VENT KIT INSTALLATION

## Roof Termination

1. Determine the best location for the termination kit.

**NOTE:** A roof termination is less susceptible to damage. It has reduced chances for intake contaminants and less visible vent vapors.

2. Cut a hole in the roof 5" in diameter for 3" concentric vent kit.

3. Partially assemble concentric vent termination kit.

a. Cement Y concentric fitting to larger diameter kit pipe

(see Fig. 1).

b. Cement vent cap to smaller diameter kit pipe (see Fig. 1).

4. Install Y concentric fitting and pipe assembly through the hole in the roof and field supplied boot/flashing. **NOTE:** Do not allow insulation or other material to accumulate inside the pipe assembly when installing through the hole.

5. Secure assembly to roof structure as shown in Fig. 4 using field supplied metal strapping or equivalent support material.

**NOTE:** Ensure termination height is above the roof surface or anticipated snow level (1' in USA or 1 1/2' in Canada) as shown in Fig 3.

**NOTE:** If assembly is too short to meet height requirements, the two pipes supplied in the kit may be replaced by using same diameter, field supplied SDR-26 PVC (D2241) pipe. Do not extend dimension D more than 60" (See Fig. 4.) **DO NOT USE COUPLINGS TO EXTEND PIPE.**

**NOTE:** When shortening the length of the concentric vent, the inner pipe is longer than the outer pipe. Make sure you cut the same amount from each pipe. **DO NOT** make the pipes equal in length.

6. Install vent cap and small diameter pipe assembly in roof penetration assembly. Ensure small diameter pipe is cemented and bottomed in Y concentric fitting.

7. Cement air inlet and exhaust vent pipes to concentric vent termination assembly. See Fig. 4 for proper pipe attachment.

8. Operate boiler through a heating cycle to ensure air inlet and exhaust vent pipes are properly connected to concentric vent termination connections.

**NOTE:** Multiple vertical venting is not allowed

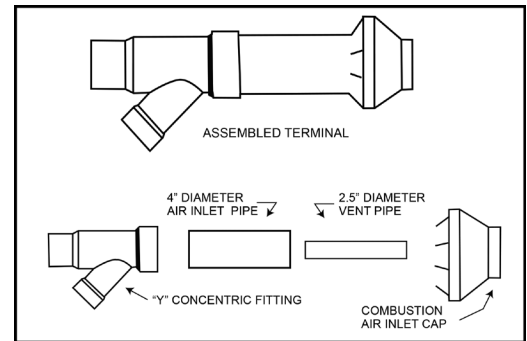

Figure 1 - Vent Terminal Assembly

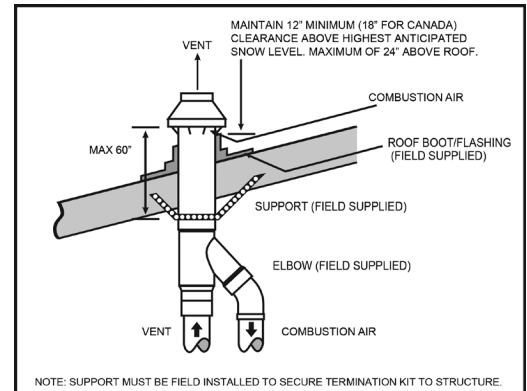

Figure 4 - Roof Installation

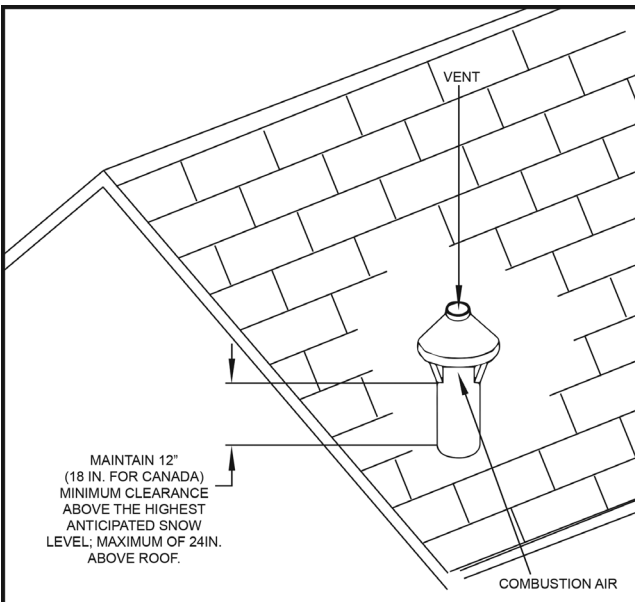

Figure 3 - Roof Termination

**WARNING:**  
 It is very important to properly glue all joints.  
 Failure to do so can result in property damage,  
 serious personal injury, or death.

# BRAMEC 3" CONCENTRIC VENT KIT INSTALLATION

## Sidewall Termination

1. Determine the best location for the termination kit.
  - a. Position termination kit where vent vapors will not damage plants, shrubs, air conditioning equipment, of the existing structure.
  - b. Position termination kit so it will not be affected by wind (which may cause recirculation of combustion products), airborne leaves, light snow, or fertilizer.
  - c. Position termination kit where it will not be subjected to damage from foreign objects, such as stones, balls, etc.
  - d. Position termination kit where the vent noise will not be objectionable to abutters.

2. Cut a hole in the sidewall 5" in diameter for 3" concentric vent kit.
3. Partially assemble concentric vent termination kit.
  - a. Cement the Y concentric fitting to larger diameter kit pipe (see Fig. 1).
  - b. Cement the vent cap to the smaller diameter kit pipe (see Fig. 1).

4. Install Y concentric fitting and pipe assembly through the hole.

**NOTE:** Do not allow insulation or other materials to accumulate inside pipe assembly when installing through hole.

5. Install vent cap and small diameter pipe assembly in Y concentric fitting and large pipe assembly. Ensure small diameter pipe is bottomed and cemented in Y concentric fitting.

6. Secure assembly to structure using field supplied metal strapping or equivalent support material (see Fig. 6).

**NOTE:** Ensure termination location clearance dimensions are as shown in Fig. 5.

**NOTE:** If assembly needs to be extended to allow sidewall thickness requirement, the two pipes supplied in the kit may be replaced by using the same diameter, field supplied SDR-26 (D2241) pipe. Do not extend Dimension D to more than 60" (see Fig. 6). **DO NOT USE COUPLINGS TO EXTEND PIPE.**

7. Cement air inlet and exhaust vent pipes to concentric vent termination assembly. See Fig. 6 for proper pipe attachment.
8. Operate boiler/heater through a heating cycle to ensure air inlet and exhaust vent pipes are properly connected to concentric vent termination connections.
9. Allow 8" center-to-center distance between concentric vent terminations on multiple boiler installations (see Fig. 7).

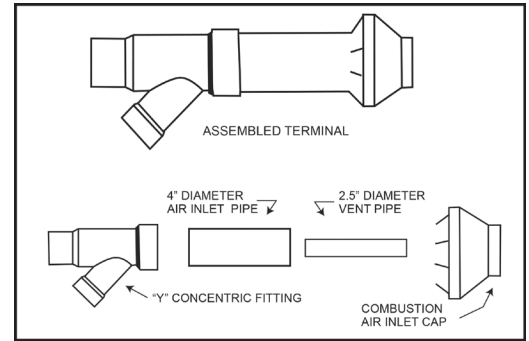

Figure 1 - Vent Terminal Assembly

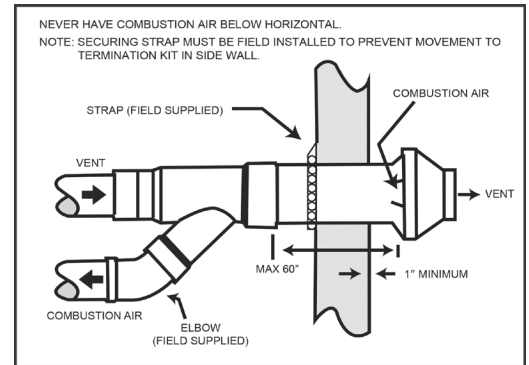

Figure 6 - Sidewall Installation

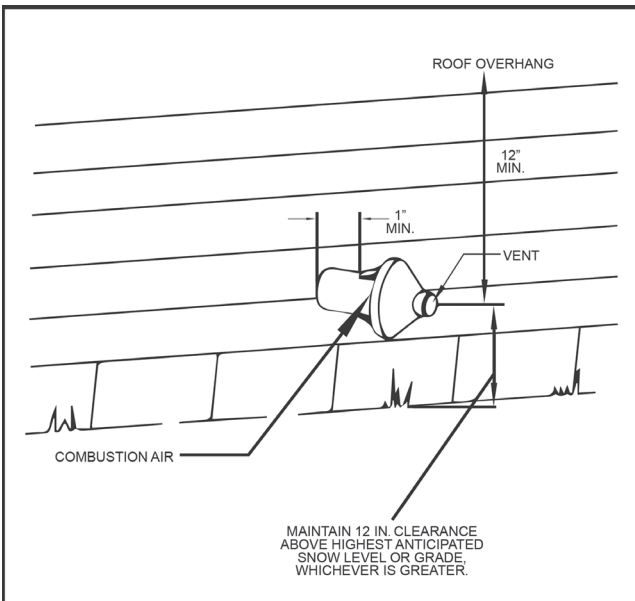

Figure 5 - Sidewall Termination

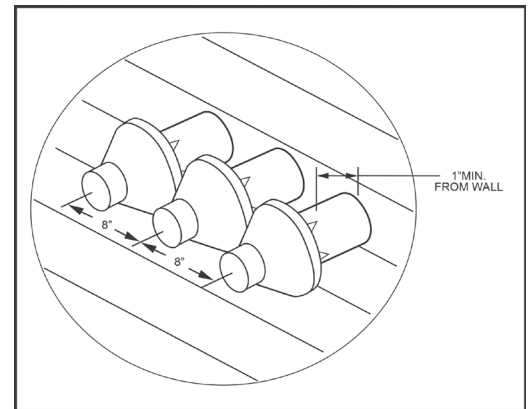

Figure 7 - Multiple Installations

**WARNING:**  
 It is very important to properly glue all joints. Failure to do so can result in property damage, serious personal injury, or death.

# Bramec 2" Concentric Vent Kit Installation

These instructions cover installation of the 3" concentric vent termination kit ONLY.

## General

The Concentric Vent allows both the intake for combustion air and the exhaust vent to pass through a standard roof or sidewall. This is an alternative to the standard two pipe intake/vent shown in the basic furnace installation instructions. Follow these instructions as well as the basic furnace installation instruction for installation of the intake/vent pipe(s) and all furnace installation procedures.

Refer to the furnace installation instructions for intake/vent pipe sizing information.

**NOTE:** The Concentric Vent reduces the allowable intake/vent piping length by 5 feet from that listed in the basic furnace installation instructions.

### WARNING:

Do not use the Concentric Vent kit for anything other than a Category IV furnace. Failure to follow this warning could result in fire, personal injury or death.

### WARNING:

Do not operate the furnace until the installation and assembly of the Concentric Vent and all piping are completed. Failure to follow this warning could result in product damage or improper operation, personal injury or death.

## This Kit contains the following parts:

- Combustion Air Inlet Cap
- Air Inlet Pipe
- Vent Pipe
- Intake/Vent Concentric "Y"

Pipe and fittings are required to complete installation (user supplied). The combustion air and vent pipe fittings must conform to ANSI and ASTM standards D1785, F891, D2665, D2241, D2661, or F628. Pipe cement and primer must conform to ASTM standards D2564 or D2235.

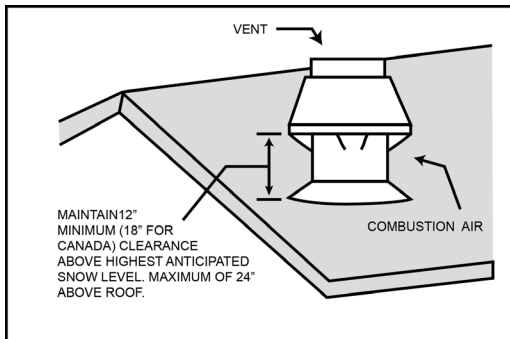
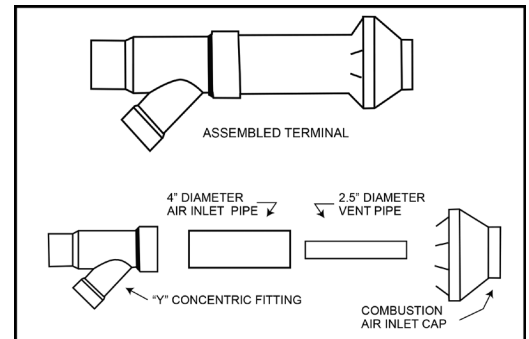

INTAKE/VENT NOM. PIPE SIZE	OVERALL ASSEM'T'D LENGTH <sup>1</sup>	INTAKE PIPE OUTSIDE DIAMETER	AIR INLET PIPE LENGTH <sup>2</sup>
2"	34-3/4"	3-1/2"	19-1/2"
3"	39-1/8"	4-1/2"	24"

1. Shipping dimension. This may be field modified by cutting or extending both the intake and exhaust pipes. 12" is the minimum allowable length and 60" is the maximum allowable length for this dimension. SDR-26 PVC (D2241) only may be used for extending pipes. Do not extend pipes with same diameter PVC or couplings.
2. This dimension will change if the intake/vent pipes are lengthened or shortened.

### NOTICE:

Some local code inspectors are not familiar with concentric vents. Be sure to check local code requirements and acceptability prior to installation.