

Mini Split Bracket

Installation Instruction

Item number
20915

- ① Completely unfold arms.

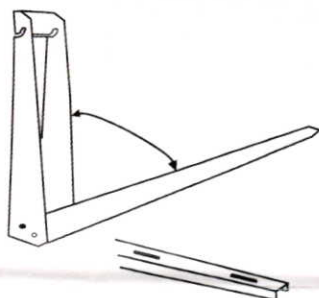

- ② Secure leveling screws and bolts to arms.
Secure mounting wall anchor screws with at least two into arms.
Secure bolts and anti vibration pads set.
Recheck all bolts and nuts for tightness and insure everything is secure before mounting any equipment.

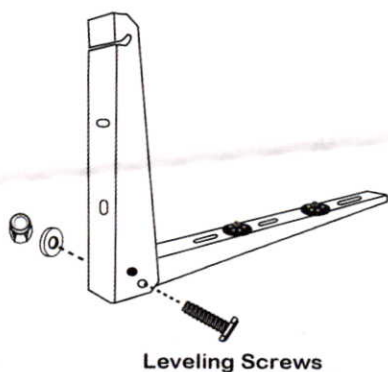

Leveling Screws

Note:
Slight rearward tilt to wall is recommended for safety purposes.

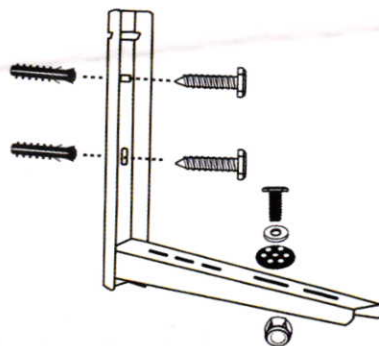

ACCESSORY PACKAGE

PACKAGE 1



x 4 x 4

PACKAGE 2

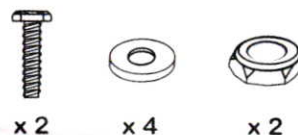

x 2 x 4 x 2

PACKAGE 3

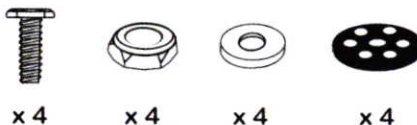

x 4 x 4 x 4 x 4

PACKAGE 1 — WALL ANCHORS SCREWS TO BE USED WITH ARMS.

PACKAGE 2 — LEVELING SCREWS FOR SECURING THE ARMS IN PLACE.

PACKAGE 3 — ANTI-VIBRATION PADS AND BOLTS TO BE USED WITH ARMS

NOTE:

1. Ensure that the wall bracket is mounted properly to handle applied load as wall construction may vary.
2. The wall bracket must be securely fixed to wall with all screws fastened tightly.
3. Do not make any modification to bracket assembly or fixings.
4. Check that all screws and bolts are secured tightly before placing the unit on it.
5. Bracket is designed for masonry wall mount, for stud wall mount proper blocking must be made between studs to insure proper wall bracing will accommodate bracket weight load.



Do not exceed maximum load 440LBS